

Ganged switch:
 1: Super Probe
 2: Line high sensitivity (2.7Vtt max)
 3: Line low sensitivity (30Vtt max)

Audio gain potentiometer is located on power board.

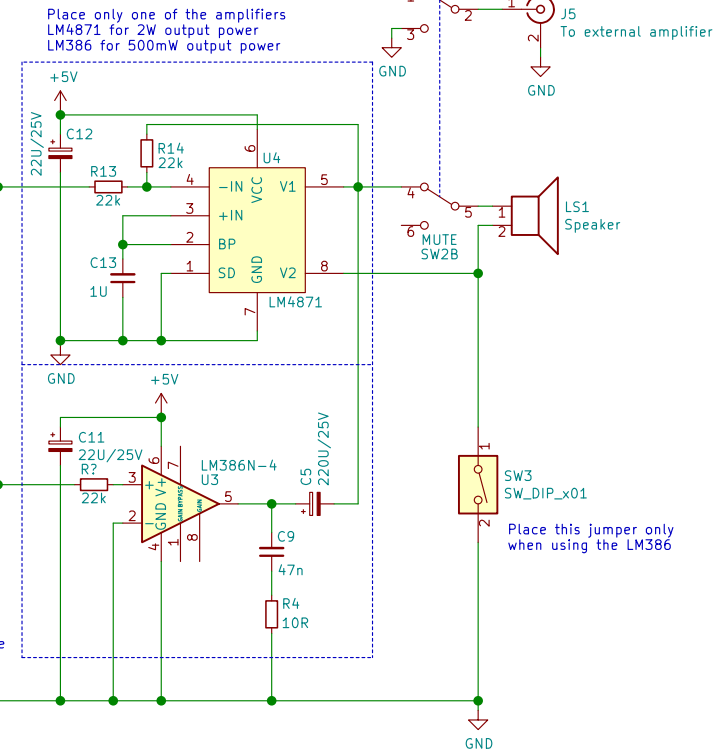
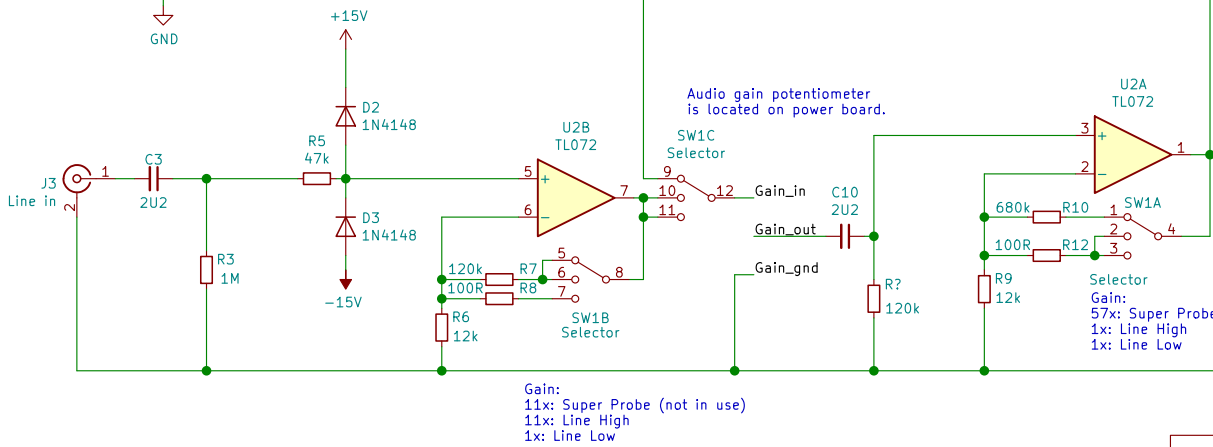

- H1 MountingHole
- H2 MountingHole
- H3 MountingHole
- H4 MountingHole

Met aansluiting voor Paul Carlson's Super Probe
M.T. Konstapel

Sheet: /
 File: superprobe.sch

Title: Signal tracer

Size: A4 Date: 11 mei 2019
 KiCad E.D.A. kicad 5.1.2-5.1.2

Rev: 1
 Id: 1/1