

Elaborate reset of some kind

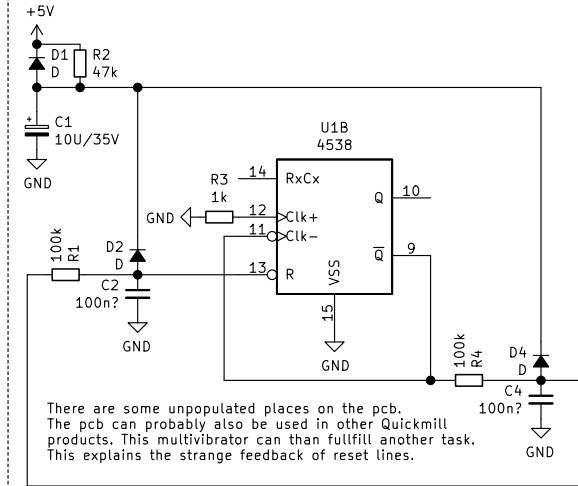

Timer

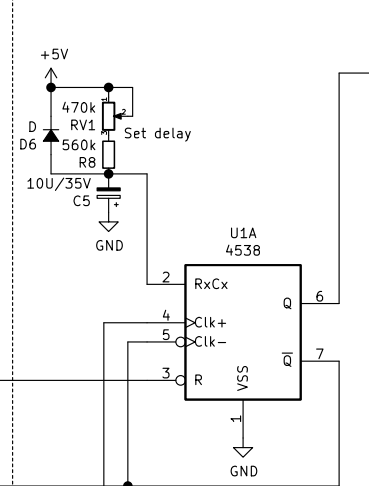

Relay driver

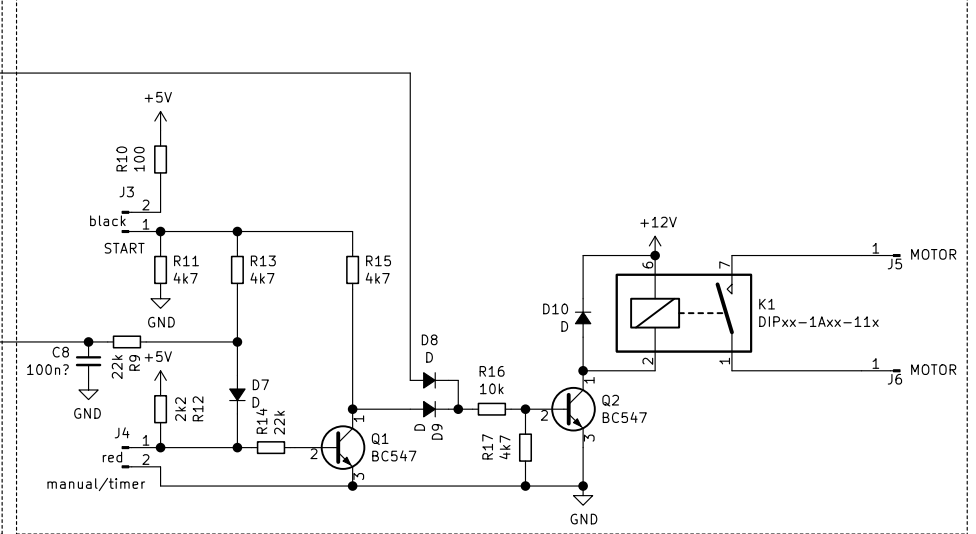

Power supply

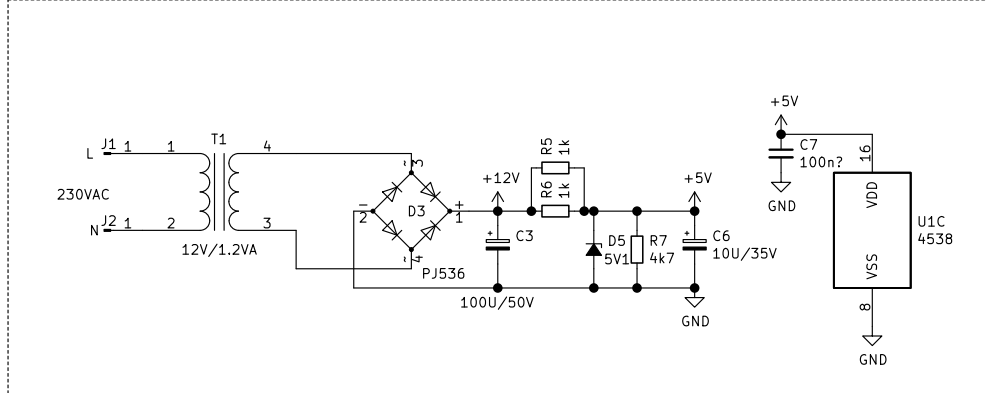

Reverse engineered schematic of Quickmill 060-0-EVO-A grinder. Probably accurate, but no warranties.

meezenest.nl/mees

M. Konstapel

Sheet: /

File: reverse-engineering.sch

Title: Quickmill coffee bean grinder

Size: A4 Date: 2022-05-26

KiCad E.D.A. kicad 5.1.8-5.1.8

MEES

Rev: A

Id: 1/1