

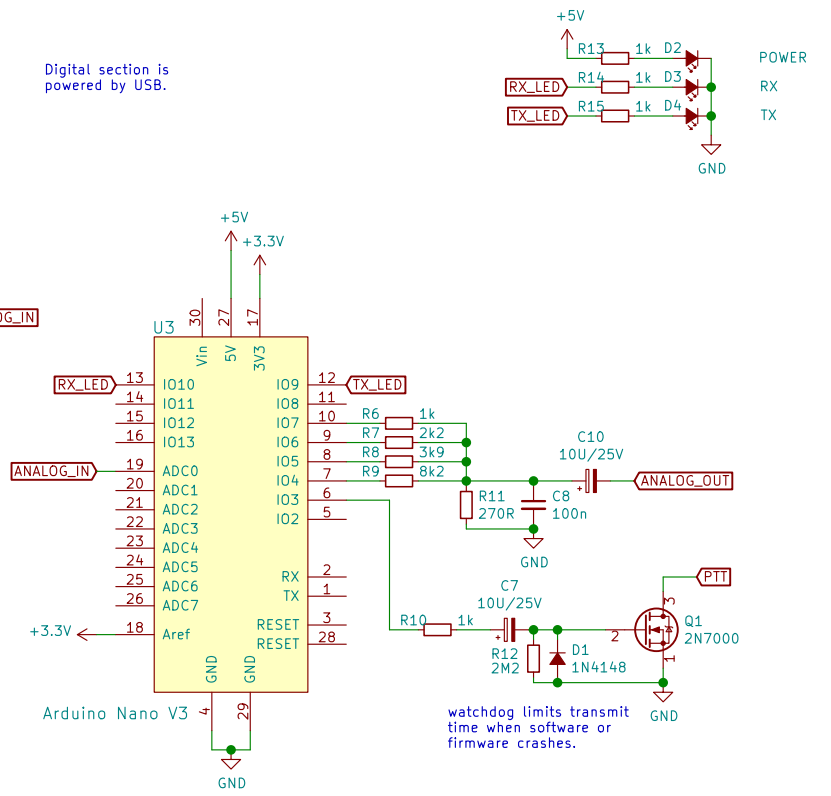

Digital section is powered by USB.



1200 baud modem with USB  
interface, using KISS protocol.

-  H1  
MountingHole
-  H2  
MountingHole
-  H3  
MountingHole
-  H4  
MountingHole



**M. Konstapel**  
Sheet: /  
File: packetmodem\_nano.sch

---

**Title: Packet modem Nano**

Size: A4	Date: 2020-06-04
KiCad E.D.A. kicad 5.1.2-5.1.2	
Rev: 1	
Id: 1/1	