

WM-509

SERVICE MANUAL

AEP Model
UK Model
E Model

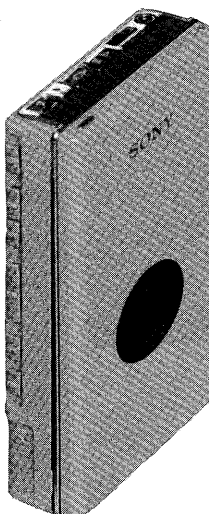

CABINET COLOR: WHITE, BLACK

Model Name Using Similar Mechanism	WM-109
Tape Transport Mechanism	MT-WM509-109

SPECIFICATIONS

Frequency response (DOLBY NR off)

20–18,000Hz

Output

Earphones (stereo minijack) load impedance
8–300Ω

Power output

4.5mW + 4.5mW (at 10% harmonic distortion),
load impedance 18 ohms

Power requirements

1.5V DC

Rechargeable battery

One R6 (size AA) battery

DC IN 1.5V jack accepts:

optional Sony AC-D1M AC power adaptor Stereo
available in the United Kingdom for use on
240V AC, 50Hz

available in European countries for use on
220V AC, 50Hz

available in other countries for use on

120V AC, 50Hz or 220V AC, 50Hz

Sony EBP-10 battery case (optional) for use
with two R6 (size AA) batteries

Sony DCC-70 car battery cord (optional) for
use with 12V car battery

Battery life

Battery	Playback hours
Rechargeable NC-6WM fully charged	Approx. 4 hours
Sony SUM-3 (NS)	Approx. 3 hours
Sony AM3 (N)	Approx. 7.5 hours

For maximum performance we recommend the
use of alkaline batteries.

Dimensions

72.9x110x24.1 mm (w/h/d)

(2⁷/₈ x 4⁵/₁₆ x 1⁵/₁₆ inches)

Weight

Approx. 190g (6.7oz) incl. rechargeable,
not incl. other accessories

Accessories supplied

Battery case (1)

Recharging station (1)

Carrying pouch (1)

Battery charger (1)

Rechargeable battery (1)

United Kingdom and European mode
earphones (open-air type, 1)

Other models

Stereo earphones (open-air type, 1)

AC plug adaptor (1)

Dolby noise reduction manufactured under license from
Dolby Laboratories Licensing Corporation.
“DOLBY” and the double-D symbol  are trademarks of
Dolby Laboratories Licensing Corporation.

CASSETTE PLAYER
SONY[®]



Features

DBB (Dynamic Bass Boost) function for powerful mega bass sound.

The remote control buttons on the headphones allow you to operate the unite in your hand.

Auto reverse function changes the tape playback direction without turning the cassette over.

The supplied recharging station charges the rechargeable battery while it is inserted in the unite.

DOLBY NR switch for playback with DOLBY NR processed tapes.

**SECTION 1
GENERAL**

LOCATION AND FUNCTION OF CONTROLS

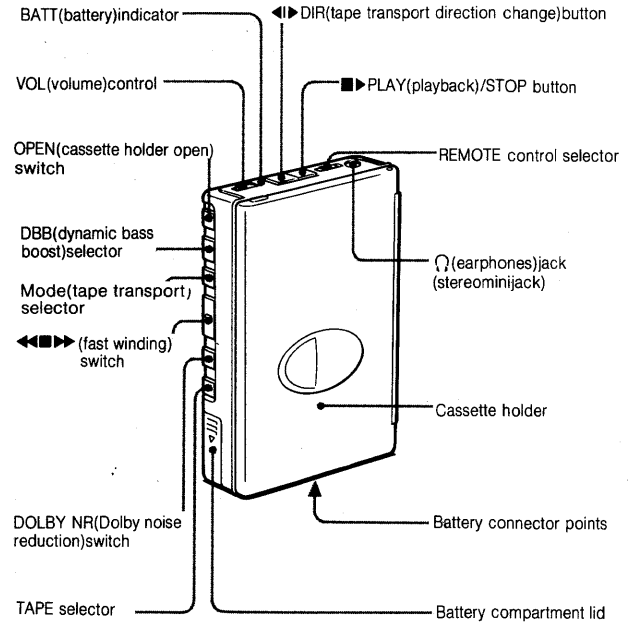

EAR RECEIVER

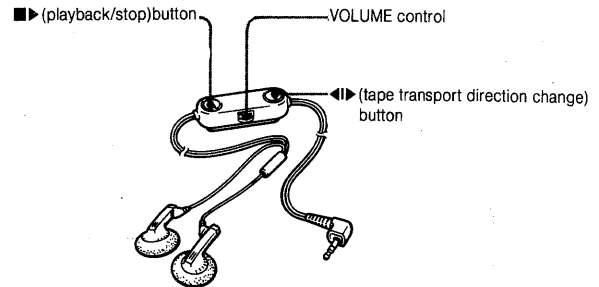

Flexible Circuit Board Repairing

Keep the temperature of the soldering iron around 270°C during repairing.

Do not touch the soldering iron on the same conductor of the circuit board (within 3 times).

Be careful not to apply force on the conductor when soldering or unsoldering.

Notes on chip component replacement

Never reuse a disconnected chip component.

Notice that the minus side of a tantalum capacitor may be damaged by heat.

SECTION 2 ADJUSTMENTS

2-1. MECHANICAL ADJUSTMENTS PRECAUTION

1. Clean the following parts with a denatured alcohol-moistened swab :

playback head	rubber belts
capstan	idlers
Cpinch roller	
2. Demagnetize the playback head with a head demagnetizer.
3. Do not use a magnetized screwdriver for the adjustments.
4. After the adjustments, apply suitable locking compound to the parts adjusted.
5. The adjustments should be performed with the rated power supply voltage (1.3V) unless otherwise noted.

Torque Measurement

Mode	Torque Meter	Meter Reading
FWD	CQ-102C	25-38g · cm 0.3-0.5 oz · inch
FWD Back Tension		1.5-3g · cm 0.02-0.04 oz · inch
REV	CQ-102RB	25-38g · cm 0.3-0.5 oz · inch
REV Back Tension		1.5-3g · cm 0.02-0.04 oz · inch
FF	CQ-201B	more than 70g · cm more than 2.4 oz · inch
REW		more than 70g · cm more than 2.4 oz · inch

Tape Pulling Force Measurement

Mode	Tension Meter	Meter Reading
FWD	CQ-403A	more than 60g more than 2.11 oz
REV	CQ-403R	more than 60g more than 2.11 oz

TEST TAPE

Type	Signal	Used for
WS-48A	3kHz, 0dB	Tape Speed Adjustment
P-4-A063	6.3kHz, -10dB	Playback Head Azimuth Adjustment
P-4-L300	315Hz, 0dB	Playback Level Adjustment

2-2. ELECTRICAL ADJUSTMENTS

Tape Speed Adjustment

Procedure :

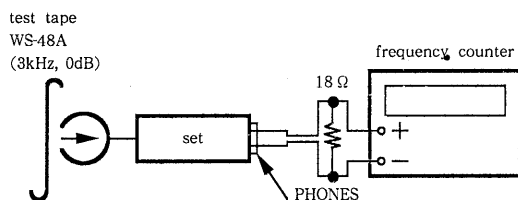

1. Playback WS-48A (Tape center portion) in FWD mode. Adjust the RV601 so that the frequency counter reads $3,000\text{Hz} \pm 15\text{Hz}$.
2. Playback WS-48A (Tape center portion) in REV mode. Confirm that the reading of frequency counter is within 1.5% from the reading in step 1.

Playback Head Azimuth Check

Note : This set is not featured the head azimuth adjustment.

When replacing the head, check the both L-ch and R-ch output levels and also those phases.

Procedure :

1. Playback mode

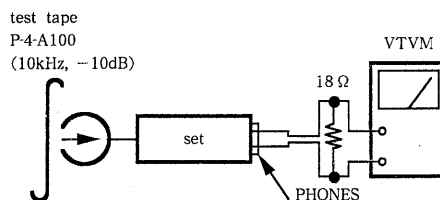

2. Phase Check

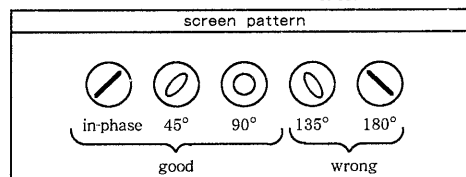
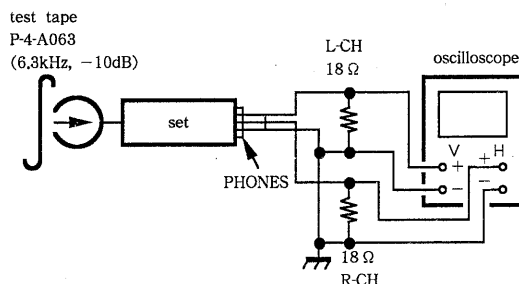

Playback Level Adjustment

- DOLBY NR switch.....OFF
- VOL knob.....MINIMUM
- DBB switch.....1 (NORM)
- TAPE.....NORM

Procedure :

1. Playback mode

test tape
P-4-L300
(315Hz, 0dB)

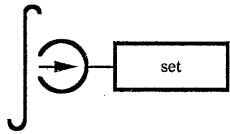

2. Adjust RV101(L-CH), RV201(R-CH) so that the VTVM reading is $-32.7 \pm 1.0\text{dB}(0.02\text{V} - 0.016\text{V})$

Adjustment Location : MAIN BOARD (SIDE A)

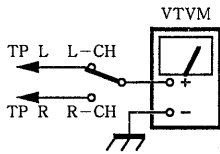

Adjustment Parts Location Diagram

MAIN BOARD (SIDE A)

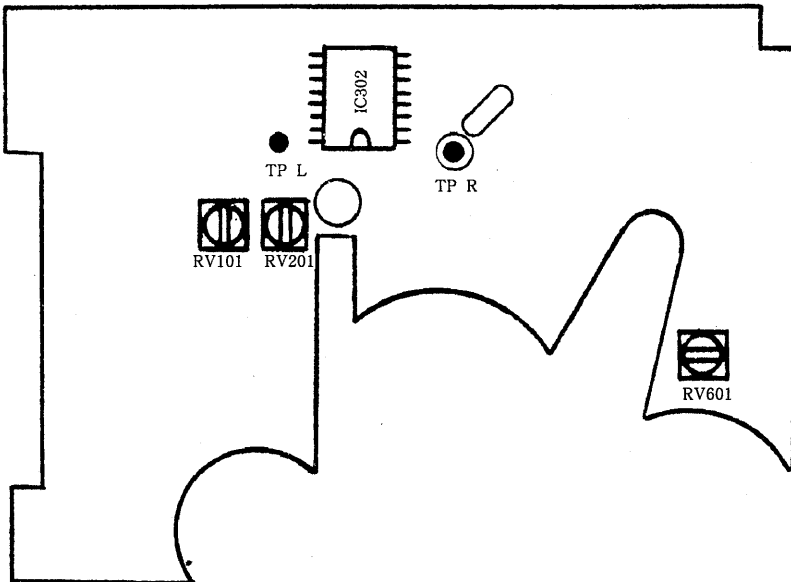

SECTION 3 DIAGRAMS

IC BLOCK DIAGRAMS

IC301 TA7795F

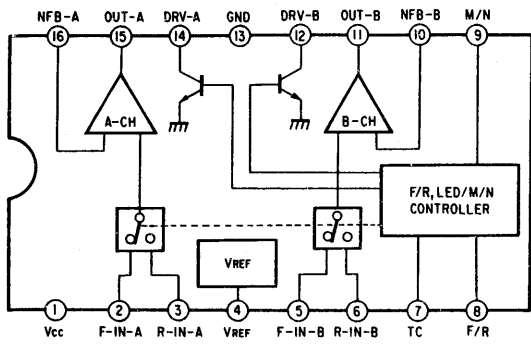

IC401 TA8133F

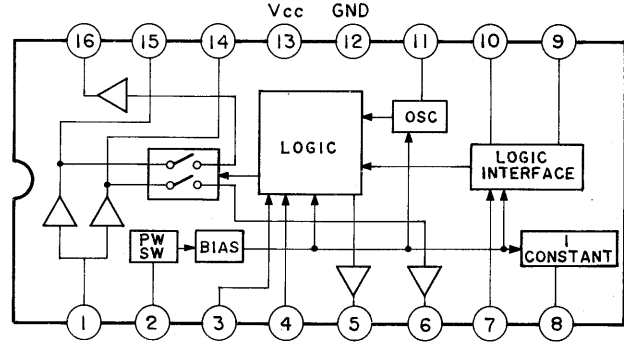

IC302 TA7793F

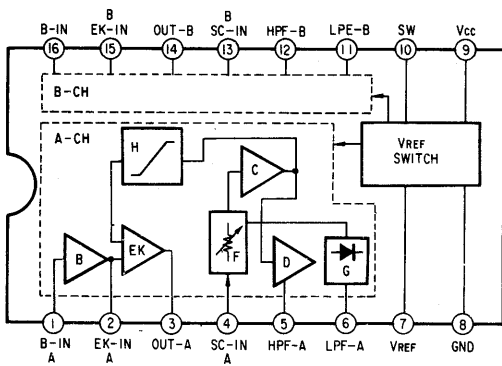

IC601 AN6653S

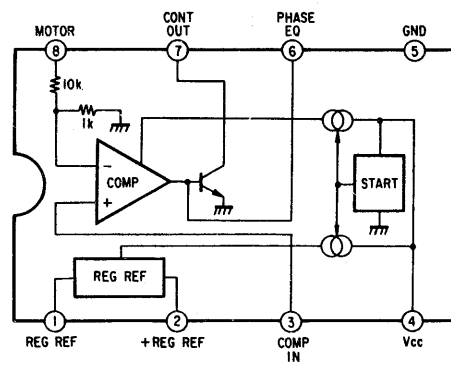

IC303 CXA-1249M

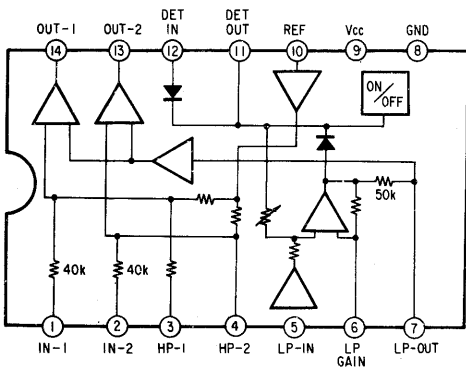

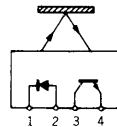

PH401 NJL5141E-AB

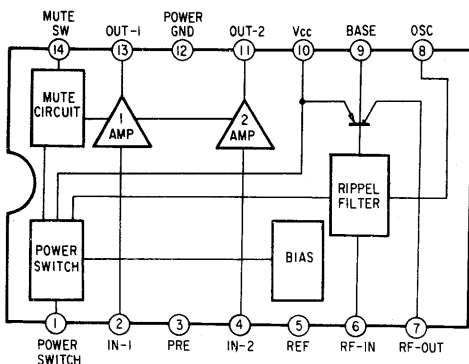

IC304 LA4538M

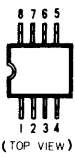

Semiconductor Lead Layouts

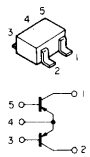
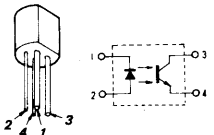
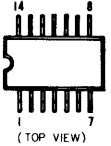
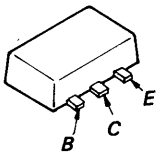
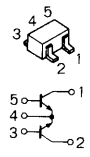
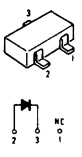
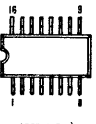
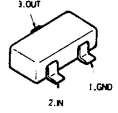
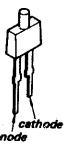
<p>AN6653</p>  <p>(TOP VIEW)</p>	<p>2SA1602 2SB815 2SB1295-UL6 2SC4154 2SD1048 DTA114TK</p> 	<p>XN1115</p> 	<p>NJL5141E-AB</p> 
<p>CXA1249M LA4538M</p>  <p>(TOP VIEW)</p>	<p>2SB798</p> 	<p>XN1501 XN1215</p> 	<p>SB007-03CP</p> 
<p>TA7793F TA7795F TA8133F</p>  <p>(TOP VIEW)</p>	<p>DTA114TU DTC114TU</p> 	<p>GL-2PR9</p> 	

SEMICONDUCTOR LOCATION

Ref.No.	Location
D401	C-2
D402	E-8
D403	B-18
IC301	E-5
IC302	B-6
IC303	B-4
IC304	F-3
IC401	C-7
IC601	D-9
PH401	D-3
Q301	G-3
Q302	G-19
Q303	G-19
Q401	D-7
Q402	D-7
Q403	D-8
Q404	C-9
Q405	C-8
Q407	B-14
Q408	B-14
Q409	B-13
Q410	B-14
Q411	B-13
Q412	B-10
Q413	C-10
Q414	B-10
Q415	D-8
Q416	C-16
Q420	B-19
Q421	B-9
Q422	B-7
Q423	B-16
Q424	C-16
Q425	D-16
Q426	C-10
Q427	C-9
Q428	D-8
Q431	B-14
Q432	B-14
Q434	C-16
Q435	D-3
Q601	C-9

See page 5, 6 for IC BLOCK DIAGRAMS and SEMICONDUCTOR LEAD LAYOUTS.

PRINTED WIRING BOARDS

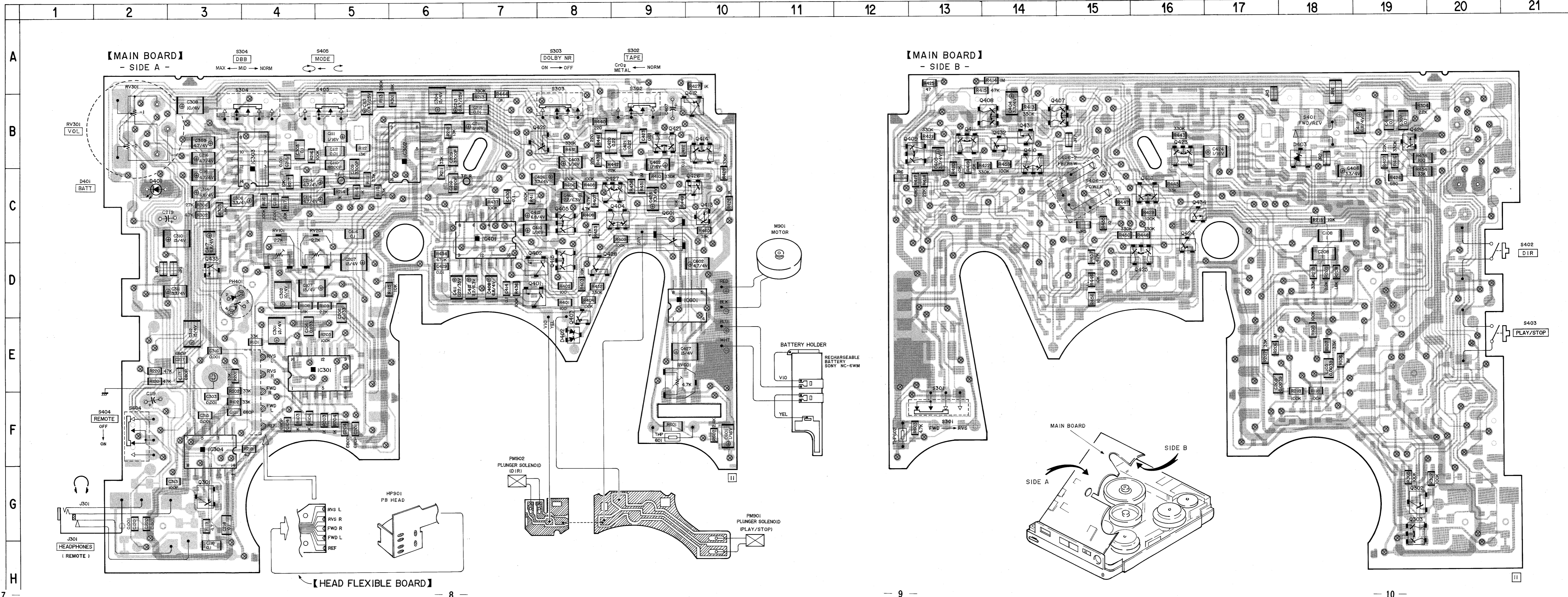

Note:
 ○ : parts extracted from the component side.
 ● : parts extracted from the conductor side.
 ■ : parts mounted on the conductor side.
 ⊗ : Through hole.
 ⊙ : Pattern on the side which is seen.
 ⊙ : Pattern of the rear side.

SCHEMATIC DIAGRAM

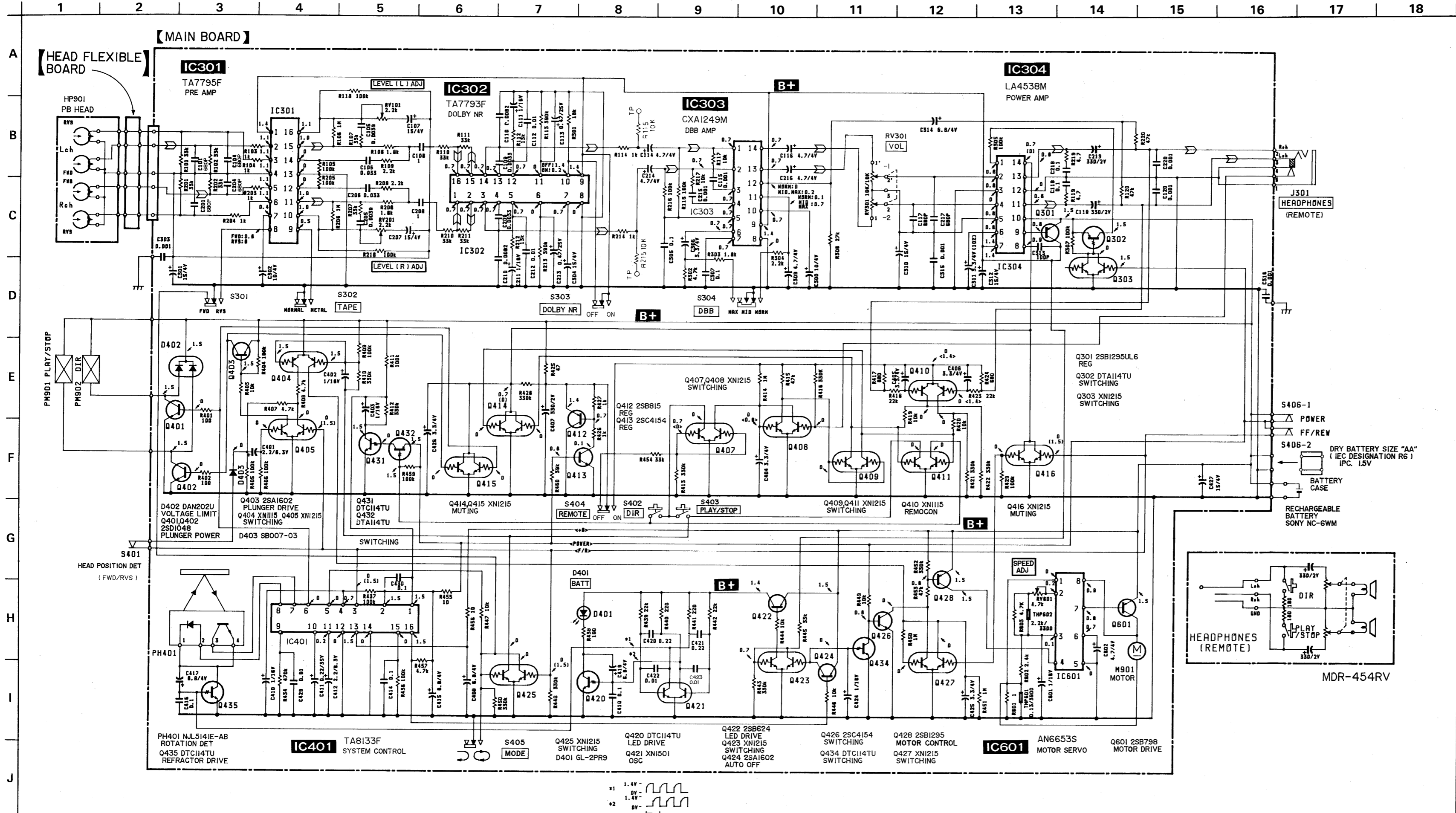

Note:
 All capacitors are in μF unless otherwise noted. $\text{pF} = \mu\mu\text{F}$
 50WV or less are not indicated except for electrolytics and tantalums.
 All resistors are in Ω and $\frac{1}{10}\text{W}$ or less unless otherwise specified.

• Switch

Ref. No.	Switch	Position
S301	FWD/R	FWD
S302	TAPE	NORMAL
S303	DOLBY NR	ON
S304	DBB	MID
S401	HEAD POSITION DET	FWD
S402	DIR	OFF
S403	PLAY/STOP	STOP
S404	REMOTE	OFF
S405	MODE	OFF
S406	POWER, FF/REM	OFF

- : B+ Line
- : adjustment for repair.
- Total current is measured with no cassette installed.
- Power voltage is dc 1.5V and fed with regulated dc power supply from external power voltage jack.
- Voltage and waveforms are dc with respect to ground under no-signal (detuned) conditions.
 no mark: PLAY
 () : FF, REW
 < > : PLAY (REMCON)
- Voltages are taken with a VOM (50 k Ω /V).
 Voltage variations may be noted due to normal production tolerances.
- Signal path.
 : PB

SECTION 4 EXPLODED VIEWS AND PARTS LIST

NOTE:

The mechanical parts with no reference number in the exploded views are not supplied.

The construction parts of an assembled part are indicated with a collation number in the remark column.

Items marked "★" are not stocked since they are seldom required for routine service. Some delay should be anticipated when ordering these items.

Due to standardization, parts with part number suffix -XX and -X may be different from the parts specified in the components used on the set.

- Color Indication of Appearance Parts
Example:

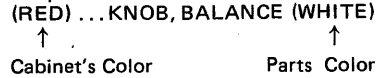

The components identified by mark or dotted line with mark are critical for safety. Replace only with part number specified.

(1)

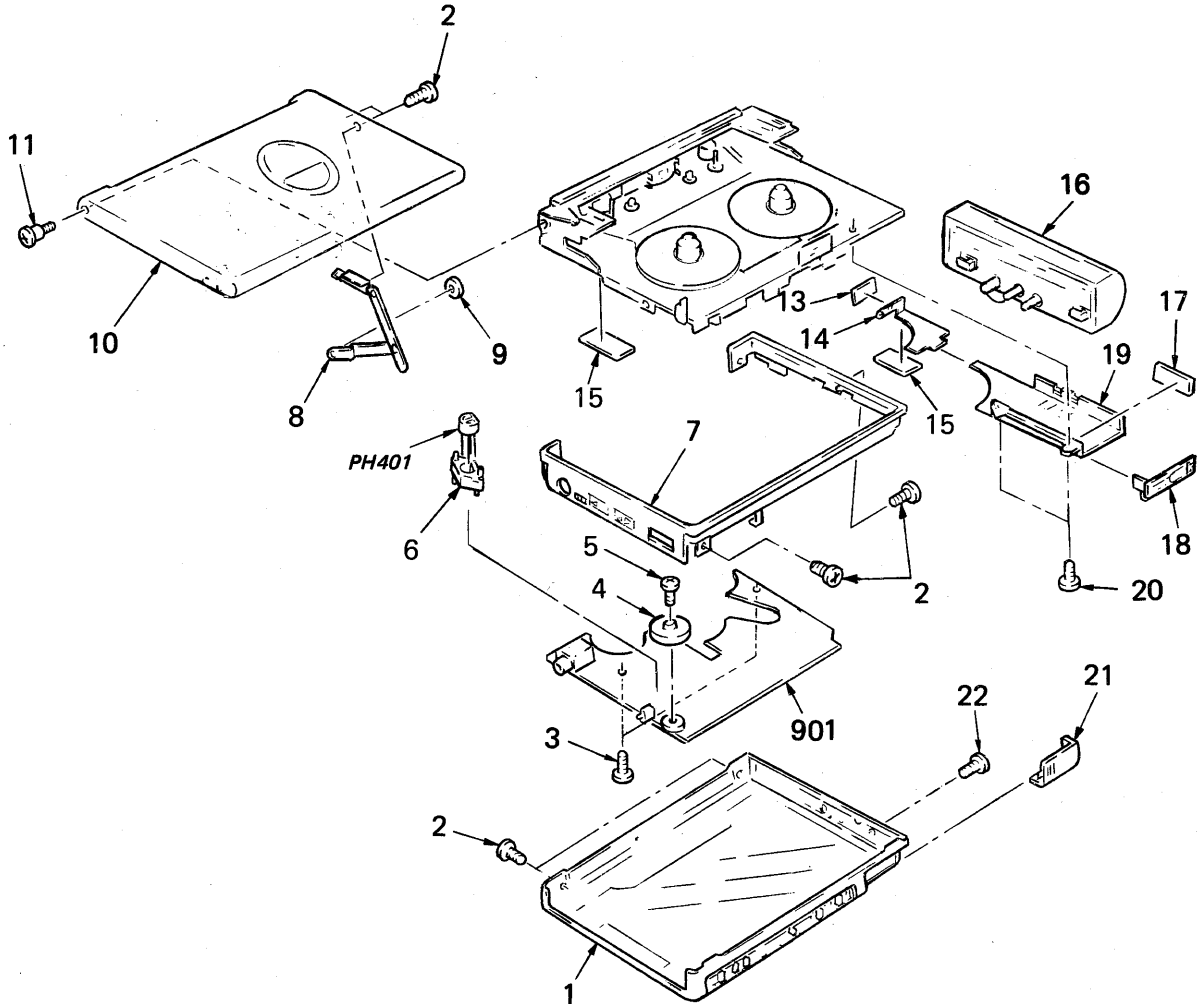

No.	Part No.	Description	Remarks	No.	Part No.	Description	Remarks
1	X-3342-390-1	CASE ASSY (W)		11	3-704-258-01	SCREW	
	X-3342-391-1	CASE ASSY (B)		13	3-342-396-01	SPACER	
2	3-704-197-11	SCREW (M1.4X2.0), NYLON		14	3-342-322-01	TERMINAL BOARD, MINUS	
3	3-704-197-01	SCREW (M1.4X2), TOOTHED LOCK		15	3-831-441-XX	CUSHION	
4	3-341-418-01	KNOB, VOL		16	1-528-258-11	BATTERY CASE	
5	3-704-197-31	SCREW (M1.4X3.0), NYLON		17	*3-342-509-01	CUSHION	
6	3-344-679-01	ADJUSTOR, REFLECTOR		18	X-3342-310-1	TERMINAL ASSY, PLUS	
7	X-3342-398-1	ORNAMENT ASSY, REEL		19	1-537-161-11	TERMINAL BOARD (BATTERY)	
8	X-3342-389-1	ARM ASSY, CLICK		20	3-347-208-01	NYLON +P 1.4X4.7 CR	
9	3-325-394-01	WASHER, STOPPER		21	3-344-673-01	LID, BATTERY CASE	
10	X-3342-394-1	LID ASSY (W), CASSETTE			3-344-673-11	LID, BATTERY CASE	
	X-3342-395-1	LID ASSY (B), CASSETTE		22	3-704-197-51	SCREW (M1.4X3.5), NYLON	
				901	A-3015-641-A	MOUNTED PCB, AUDIO	
				PH401	8-719-751-43	DIODE NJL5141E-AB	

SEE ADDITIONAL
INFORMATION

REVISED

WM-509

(2)

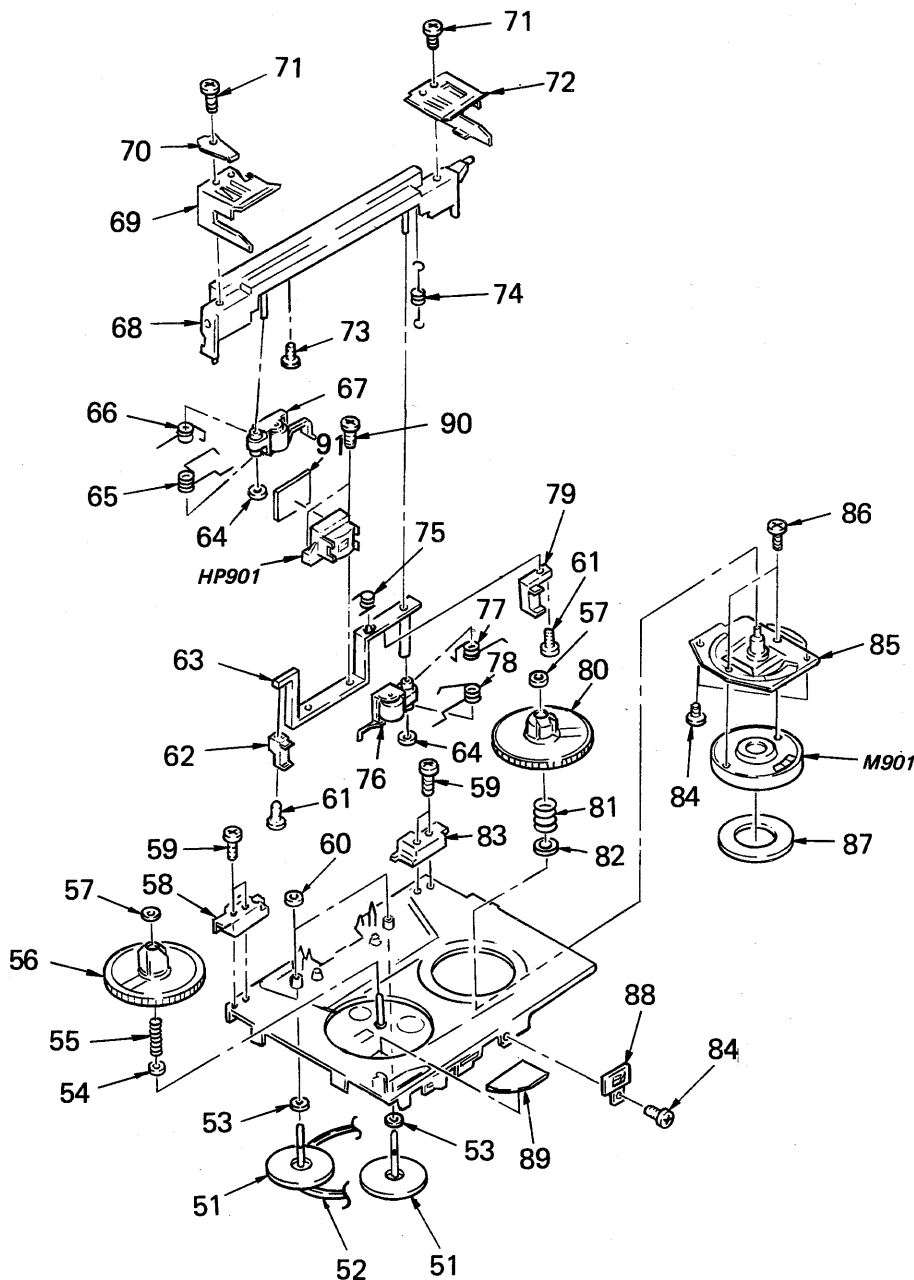

No.	Part No.	Description	Remarks	No.	Part No.	Description	Remarks
51	X-3331-039-1	WHEEL (F2) ASSY, CAPSTAN		72	3-329-713-21	HOLDER (LEFT), CASSETTE	
52	3-329-695-01	BELT		73	3-704-382-21	SCREW (1.4X2)	
53	3-321-394-21	WASHER		74	3-341-474-01	SPRING, TENSION	
54	3-315-415-21	WASHER (1.5-2.3)		75	3-347-205-01	SPRING (HD LEVER), TORSION	
55	3-331-013-01	SPRING, COMPRESSION		76	X-3331-035-1	PINCH LEVER (R) ASSY	
56	X-3331-049-1	GEAR ASSY, T REEL		77	3-341-468-01	SPRING (R)	
57	3-315-384-11	WASHER, STOPPER		78	3-341-467-01	SPRING (R)	
58	3-329-736-01	GUIDE (RIGHT), HOLDER		79	*3-344-693-01	GUIDE (L)	
59	3-704-244-61	SCREW (P1.7X4.0)		80	3-345-708-01	GEAR (S REEL)	
60	3-331-007-21	WASHER		81	3-345-729-01	SPRING (S), COMPRESSION	
61	3-338-687-41	SCREW (M1.4X2.5), TAPPING		82	3-320-354-01	WASHER	
62	*3-344-694-01	GUIDE (R)		83	3-329-737-01	GUIDE (LEFT), HOLDER	
63	*3-345-725-01	LEVER ASSY, HEAD AZ		84	3-342-376-01	SCREW (M1.4), SPECIAL	
64	3-341-473-01	WASHER (MP)		85	*X-3331-041-1	BRACKET ASSY, MOTOR	
65	3-341-470-01	SPRING (N)		86	3-342-375-01	SCREW (M1.7), SPECIAL	
66	3-341-469-01	SPRING (N)		87	3-343-013-01	SHEET, MOTOR	
67	X-3331-036-1	PINCH LEVER (N) ASSY		88	3-345-707-01	SPRING	
68	X-3331-045-1	HOLDER (D) ASSY		89	*3-337-983-01	SHEET	
69	3-329-714-01	HOLDER (RIGHT), CASSETTE		90	3-331-432-81	SCREW, M1.4X4	
70	3-331-087-11	SPRING		HP901	1-543-517-11	HEAD, MAGNETIC (PLAY BACK)	
71	3-341-432-41	SCREW (M1.4X2.5), TAPPING		M901	1-541-525-11	MOTOR, DC	

(3)

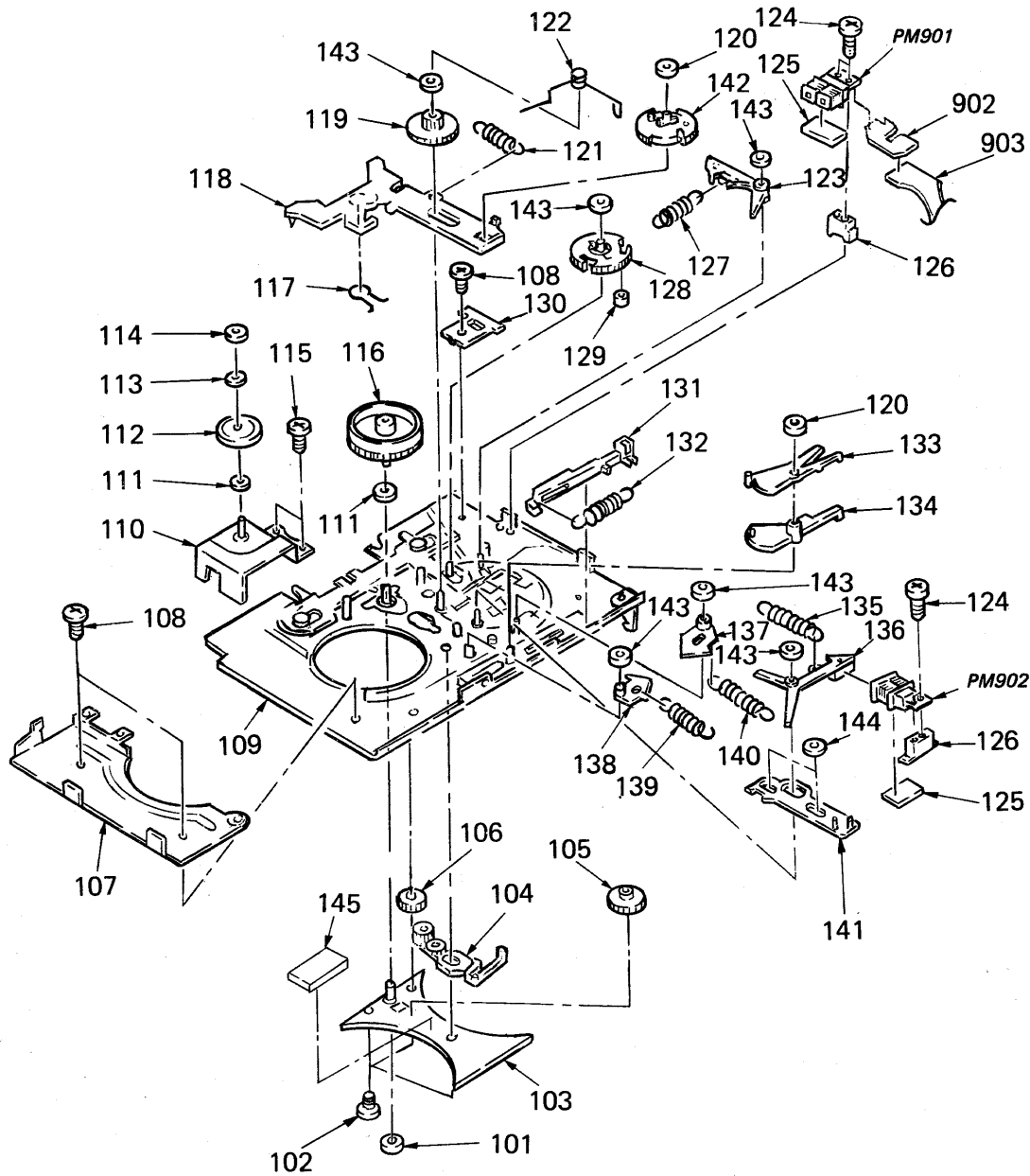

No.	Part No.	Description	Remarks	No.	Part No.	Description	Remarks
101	3-331-007-21	WASHER		126	*3-331-041-01	BRACKET, P	
102	3-331-047-01	SCREW (M1.4X1.4),SPECIAL HEAD		127	3-338-623-01	SPRING, TENSION	
103	X-3331-043-1	COVER (F) ASSY, REEL		128	3-337-911-01	GEAR (S), CAM	
104	X-3329-626-1	LEVER (B) ASSY, F.R		129	3-337-924-01	COLLAR (F), CAM GEAR	
105	3-329-688-01	GEAR (A), T		130	*3-341-483-01	REINFORCEMENT	
106	3-329-689-01	GEAR (B), T		131	3-341-497-01	SLIDER (OPEN)	
107	*3-341-493-01	BRACKET (CHASSIS)		132	3-338-610-01	SPRING (OPEN SLIDER), TENSION	
108	3-342-376-01	SCREW (M1.4), SPECIAL		133	3-341-494-01	LEVER (FA), SW	
109	X-3331-047-2	CHASSIS (F2) ASSY		134	3-341-498-01	LEVER (FB), SW	
110	X-3342-324-1	BRACKET (REVERSE) ASSY		135	3-338-611-01	SPRING, TENSION	
111	3-321-394-21	WASHER		136	X-3329-747-1	LEVER (S) ASSY, TRIGGER	
112	X-3342-338-1	PULLEY (REVERSE C) ASSY		137	*3-337-916-01	LEVER, FF	
113	3-321-394-01	WASHER		138	*3-337-917-01	LEVER, REW	
114	3-331-036-11	WASHER		139	3-338-615-01	SPRING (REW LEVER), TENSION	
115	3-703-816-11	SCREW (M1.4X2.5), SPECIAL HEAD		140	3-338-612-01	SPRING (FF REW LEVER), TENSION	
116	X-3331-044-1	PULLEY COMP ASSY, MIDWAY		141	3-341-477-01	LEVER (FP), SW	
117	3-329-698-01	SPRING (B)		142	3-341-495-01	GEAR (CAM GEAR (D))	
118	X-3329-750-1	LEVER (F) ASSY, DRIVING		143	3-331-007-01	WASHER	
119	3-337-913-01	GEAR (F), DRIVING		144	3-338-647-21	WASHER	
120	3-338-645-21	WASHER (0.8-2.5)		145	*3-338-666-01	SHEET	
121	3-338-609-01	SPRING, TENSION		902	1-617-019-21	PC BOARD, MP FLEXIBLE	
122	3-341-478-01	SPRING (TRIGGER), TORSION		903	1-621-133-11	PC BOARD, MPS FLEXIBLE	
123	X-3331-025-1	LEVER ASSY, TRIGGER		PM901	1-454-406-11	SOLENOID, PLUNGER	
124	7-627-551-37	SCREW, PRECISION +P 1.4X5		PM902	1-454-406-11	SOLENOID, PLUNGER	
125	*3-338-668-11	SHEET					

SECTION 5 ELECTRICAL PARTS LIST

NOTE:

Due to standardization, replacements in the parts list may be different from the parts specified in the diagrams or the components used on the set.

Items marked "★" are not stocked since they are seldom required for routine service. Some delay should be anticipated when ordering these items.

- If there are two or more same circuits in a set such as a stereophonic machine, only typical circuit parts may be indicated and capacitors and resistors in other same circuits may be omitted.

CAPACITORS:

MF: μ F, PF: μ F.

RESISTORS

- All resistors are in ohms.
- F: nonflammable

COILS

- MMH: mH, UH: μ H

SEMICONDUCTORS

In each case, U: μ , for example:

UA...: μ A..., UPA...: μ PA...,

UPC...: μ PC, UPD...: μ PD...

The components identified by mark Δ or dotted line with mark Δ are critical for safety. Replace only with part number specified.

Ref.No.	Part No.	Description				Ref.No.	Part No.	Description			
901	A-3015-641-A	MOUNTED PCB, AUDIO				C307	1-163-038-00	CERAMIC CHIP 0.1MF			25V
902	1-617-019-21	PC BOARD, MP FLEXIBLE				C308	1-135-104-00	TANTAL. CHIP 10MF	20%		4V
903	1-621-133-11	PC BOARD, M'S FLEXIBLE				C309	1-135-151-21	TANTAL. CHIP 4.7MF	20%		4V
C101	1-162-963-11	CERAMIC CHIP 680PF	10%		50V	C310	1-135-158-21	TANTAL. CHIP 15MF	20%		4V
C104	1-162-963-11	CERAMIC CHIP 680PF	10%		50V	C311	1-135-103-00	TANTAL. CHIP 3.3MF	10%		4V
C105	1-163-016-00	CERAMIC CHIP 0.0039MF	5%		50V	C312	1-135-158-21	TANTAL. CHIP 15MF	20%		4V
C106	1-163-034-00	CERAMIC CHIP 0.033MF	10%		25V	C313	1-162-953-11	CERAMIC CHIP 100PF	5%		50V
C107	1-135-158-21	TANTAL. CHIP 15MF	10%		4V	C314	1-135-170-21	TANTAL. CHIP 6.8MF	20%		4V
C108	1-162-611-00	CERAMIC CHIP 1MF			25V	C315	1-162-964-11	CERAMIC CHIP 0.001MF	10%		50V
C109	1-163-015-00	CERAMIC CHIP 0.0033MF	5%		50V	C316	1-162-964-11	CERAMIC CHIP 0.001MF	10%		50V
C110	1-163-020-00	CERAMIC CHIP 0.0082MF	10%		50V	C401	1-135-099-00	TANTAL. CHIP 2.2MF	20%		6.3V
C111	1-135-091-00	TANTAL. CHIP 1MF	10%		16V	C402	1-135-091-00	TANTAL. CHIP 1MF	20%		16V
C112	1-163-021-00	CERAMIC CHIP 0.01MF	5%		50V	C403	1-135-091-00	TANTAL. CHIP 1MF	20%		16V
C113	1-135-083-00	TANTAL. CHIP 0.47MF	10%		25V	C404	1-135-103-00	TANTAL. CHIP 3.3MF	20%		4V
C114	1-135-151-21	TANTAL. CHIP 4.7MF	20%		4V	C405	1-135-103-00	TANTAL. CHIP 3.3MF	20%		4V
C115	1-162-964-11	CERAMIC CHIP 0.001MF	10%		50V	C406	1-135-103-00	TANTAL. CHIP 3.3MF	20%		4V
C116	1-135-151-21	TANTAL. CHIP 4.7MF	20%		4V	C407	1-126-117-11	ELECT 330MF	20%		2V
C117	1-162-963-11	CERAMIC CHIP 680PF	10%		50V	C408	1-135-170-21	TANTAL. CHIP 6.8MF	20%		4V
C118	1-163-038-00	CERAMIC CHIP 0.1MF			25V	C410	1-135-091-00	TANTAL. CHIP 1MF	20%		16V
C119	1-126-236-11	ELECT 330MF	20%		2V	C411	1-135-072-21	TANTAL. CHIP 0.22MF	20%		35V
C120	1-162-964-11	CERAMIC CHIP 0.001MF	10%		50V	C412	1-135-099-00	TANTAL. CHIP 2.2MF	20%		6.3V
C201	1-162-963-11	CERAMIC CHIP 680PF	10%		50V	C414	1-164-156-11	CERAMIC CHIP 0.1MF			25V
C204	1-162-963-11	CERAMIC CHIP 680PF	10%		50V	C415	1-135-170-21	TANTAL. CHIP 6.8MF	20%		4V
C205	1-163-016-00	CERAMIC CHIP 0.0039MF	5%		50V	C416	1-163-038-00	CERAMIC CHIP 0.1MF			25V
C206	1-163-034-00	CERAMIC CHIP 0.033MF	10%		25V	C417	1-135-170-21	TANTAL. CHIP 6.8MF	20%		4V
C207	1-135-158-21	TANTAL. CHIP 15MF	10%		4V	C418	1-163-038-00	CERAMIC CHIP 0.1MF			25V
C208	1-162-611-00	CERAMIC CHIP 1MF			25V	C419	1-135-170-21	TANTAL. CHIP 6.8MF	20%		4V
C209	1-163-015-00	CERAMIC CHIP 0.0033MF	5%		50V	C420	1-163-081-00	CERAMIC CHIP 0.22MF			25V
C210	1-163-020-00	CERAMIC CHIP 0.0082MF	10%		50V	C421	1-163-081-00	CERAMIC CHIP 0.22MF			25V
C211	1-135-091-00	TANTAL. CHIP 1MF	10%		16V	C422	1-162-970-11	CERAMIC CHIP 0.01MF	10%		25V
C212	1-163-021-00	CERAMIC CHIP 0.01MF	5%		50V	C423	1-162-970-11	CERAMIC CHIP 0.01MF	10%		25V
C213	1-135-083-00	TANTAL. CHIP 0.47MF	10%		25V	C424	1-135-091-00	TANTAL. CHIP 1MF	20%		16V
C214	1-135-151-21	TANTAL. CHIP 4.7MF	20%		4V	C425	1-135-103-00	TANTAL. CHIP 3.3MF	20%		4V
C215	1-162-964-11	CERAMIC CHIP 0.001MF	10%		50V	C426	1-135-103-00	TANTAL. CHIP 3.3MF	20%		4V
C216	1-135-151-21	TANTAL. CHIP 4.7MF	20%		4V	C427	1-135-158-21	TANTAL. CHIP 15MF	20%		4V
C217	1-162-963-11	CERAMIC CHIP 680PF	10%		50V	C429	1-162-970-11	CERAMIC CHIP 0.01MF	10%		25V
C218	1-163-038-00	CERAMIC CHIP 0.1MF			25V	C430	1-164-156-11	CERAMIC CHIP 0.1MF			25V
C219	1-126-236-11	ELECT 330MF	20%		2V	C601	1-135-091-00	TANTAL. CHIP 1MF	20%		16V
C220	1-162-964-11	CERAMIC CHIP 0.001MF	10%		50V	C602	1-135-151-21	TANTAL. CHIP 4.7MF	20%		4V
C301	1-135-158-21	TANTAL. CHIP 15MF	20%		4V	D401	1-807-305-11	DIODE GL2PR9 (LED)			
C302	1-135-104-00	TANTAL. CHIP 10MF	20%		4V	D402	8-719-941-86	DIODE DAN202U			
C303	1-162-964-11	CERAMIC CHIP 0.001MF	10%		50V	D403	8-719-941-04	DIODE SB007-03CP			
C304	1-135-158-21	TANTAL. CHIP 15MF	20%		4V	HP901	1-543-517-11	HEAD, MAGNETIC (PLAY BACK)			
C305	1-163-038-00	CERAMIC CHIP 0.1MF			25V	IC301	8-759-208-46	IC TA7795F			
C306	1-135-103-00	TANTAL. CHIP 3.3MF	20%		4V	IC302	8-759-209-93	IC TA7793F			
						IC303	8-759-805-09	IC CXA1249M			

Ref.No.	Part No.	Description
IC304	8-759-805-02	IC LA4538M
IC401	8-759-230-37	IC TA8133F
IC601	8-759-404-15	IC AN6653S
J301	1-563-715-11	JACK
JR1	1-216-864-11	METAL GLAZE 0 5% 1/16W
JR2	1-216-864-11	METAL GLAZE 0 5% 1/16W
JR3	1-216-864-11	METAL GLAZE 0 5% 1/16W
JR4	1-216-296-00	METAL GLAZE 0 5% 1/8W
JR5	1-216-864-11	METAL GLAZE 0 5% 1/16W
JR6	1-216-864-11	METAL GLAZE 0 5% 1/16W
JR7	1-216-864-11	METAL GLAZE 0 5% 1/16W
JR8	1-216-864-11	METAL GLAZE 0 5% 1/16W
M901	1-541-525-11	MOTOR, DC
PH401	8-719-751-43	DIODE NJL5141E-AB
PM901	1-454-406-11	SOLENOID, PLUNGER
PM902	1-454-406-11	SOLENOID, PLUNGER
Q301	8-729-807-87	TRANSISTOR 2SB1295-UL5
Q302	8-729-900-51	TRANSISTOR DTA114TK
Q303	8-729-403-17	TRANSISTOR XN1215
Q401	8-729-800-36	TRANSISTOR 2SD1048
Q402	8-729-800-36	TRANSISTOR 2SD1048
Q403	8-729-602-36	TRANSISTOR 2SA1602
Q404	8-729-403-45	TRANSISTOR XN1115
Q405	8-729-403-17	TRANSISTOR XN1215
Q407	8-729-403-17	TRANSISTOR XN1215
Q408	8-729-403-17	TRANSISTOR XN1215
Q409	8-729-403-17	TRANSISTOR XN1215
Q410	8-729-403-45	TRANSISTOR XN1115
Q411	8-729-403-17	TRANSISTOR XN1215
Q412	8-729-800-68	TRANSISTOR 2SB815
Q413	8-729-602-21	TRANSISTOR 2SC4154
Q414	8-729-403-17	TRANSISTOR XN1215
Q415	8-729-403-17	TRANSISTOR XN1215
Q416	8-729-403-17	TRANSISTOR XN1215
Q420	8-729-905-99	TRANSISTOR DTC114TU
Q421	8-729-402-13	TRANSISTOR XN1501
Q422	8-729-800-68	TRANSISTOR 2SB815
Q423	8-729-403-17	TRANSISTOR XN1215
Q424	8-729-602-36	TRANSISTOR 2SA1602
Q425	8-729-403-17	TRANSISTOR XN1215
Q426	8-729-602-21	TRANSISTOR 2SC4154
Q427	8-729-403-17	TRANSISTOR XN1215
Q428	8-729-807-87	TRANSISTOR 2SB1295-UL6

Ref.No.	Part No.	Description
Q431	8-729-905-99	TRANSISTOR DTC114TU
Q432	8-729-905-96	TRANSISTOR DTA114TU
Q434	8-729-905-99	TRANSISTOR DTC114TU
Q435	8-729-905-99	TRANSISTOR DTC114TU
Q601	8-729-101-67	TRANSISTOR 2SB798
R101	1-216-839-11	METAL GLAZE 33K 5% 1/16W
R102	1-216-839-11	METAL GLAZE 33K 5% 1/16W
R103	1-216-821-11	METAL GLAZE 1K 5% 1/16W
R104	1-216-821-11	METAL GLAZE 1K 5% 1/16W
R105	1-216-845-11	METAL GLAZE 100K 5% 1/16W
R106	1-216-857-11	METAL GLAZE 1M 5% 1/16W
R107	1-216-839-11	METAL GLAZE 33K 5% 1/16W
R108	1-216-824-11	METAL GLAZE 1.8K 5% 1/16W
R109	1-216-825-11	METAL GLAZE 2.2K 5% 1/16W
R110	1-216-839-11	METAL GLAZE 33K 5% 1/16W
R111	1-216-839-11	METAL GLAZE 33K 5% 1/16W
R112	1-216-994-11	METAL GLAZE 13K 5% 1/16W
R113	1-216-852-11	METAL GLAZE 390K 5% 1/16W
R114	1-216-821-11	METAL GLAZE 1K 5% 1/16W
R115	1-216-833-11	METAL GLAZE 10K 5% 1/16W
R116	1-216-845-11	METAL GLAZE 100K 5% 1/16W
R117	1-216-833-11	METAL GLAZE 10K 5% 1/16W
R118	1-216-845-11	METAL GLAZE 100K 5% 1/16W
R119	1-216-793-11	METAL GLAZE 4.7 5% 1/16W
R120	1-216-841-11	METAL GLAZE 47K 5% 1/16W
R201	1-216-839-11	METAL GLAZE 33K 5% 1/16W
R202	1-216-839-11	METAL GLAZE 33K 5% 1/16W
R203	1-216-821-11	METAL GLAZE 1K 5% 1/16W
R204	1-216-821-11	METAL GLAZE 1K 5% 1/16W
R205	1-216-845-11	METAL GLAZE 100K 5% 1/16W
R206	1-216-857-11	METAL GLAZE 1M 5% 1/16W
R207	1-216-839-11	METAL GLAZE 33K 5% 1/16W
R208	1-216-824-11	METAL GLAZE 1.8K 5% 1/16W
R209	1-216-825-11	METAL GLAZE 2.2K 5% 1/16W
R210	1-216-839-11	METAL GLAZE 33K 5% 1/16W
R211	1-216-839-11	METAL GLAZE 33K 5% 1/16W
R212	1-216-994-11	METAL GLAZE 13K 5% 1/16W
R213	1-216-852-11	METAL GLAZE 390K 5% 1/16W
R214	1-216-821-11	METAL GLAZE 1K 5% 1/16W
R215	1-216-833-11	METAL GLAZE 10K 5% 1/16W
R216	1-216-845-11	METAL GLAZE 100K 5% 1/16W
R217	1-216-833-11	METAL GLAZE 10K 5% 1/16W
R218	1-216-845-11	METAL GLAZE 100K 5% 1/16W
R219	1-216-793-11	METAL GLAZE 4.7 5% 1/16W

Ref.No.	Part No.	Description				
R220	1-216-841-11	METAL GLAZE	47K	5%	1/16W	
R301	1-216-836-11	METAL GLAZE	18K	5%	1/16W	
R302	1-216-829-11	METAL GLAZE	4.7K	5%	1/16W	
R303	1-216-824-11	METAL GLAZE	1.8K	5%	1/16W	
R304	1-216-825-11	METAL GLAZE	2.2K	5%	1/16W	
R305	1-216-845-11	METAL GLAZE	100K	5%	1/16W	
R306	1-216-838-11	METAL GLAZE	27K	5%	1/16W	
R307	1-216-845-11	METAL GLAZE	100K	5%	1/16W	
R401	1-216-809-11	METAL GLAZE	100	5%	1/16W	
R402	1-216-809-11	METAL GLAZE	100	5%	1/16W	
R403	1-216-833-11	METAL GLAZE	10K	5%	1/16W	
R404	1-216-845-11	METAL GLAZE	100K	5%	1/16W	
R405	1-216-845-11	METAL GLAZE	100K	5%	1/16W	
R406	1-216-845-11	METAL GLAZE	100K	5%	1/16W	
R407	1-216-829-11	METAL GLAZE	4.7K	5%	1/16W	
R408	1-216-829-11	METAL GLAZE	4.7K	5%	1/16W	
R409	1-216-845-11	METAL GLAZE	100K	5%	1/16W	
R410	1-216-851-11	METAL GLAZE	330K	5%	1/16W	
R411	1-216-845-11	METAL GLAZE	100K	5%	1/16W	
R412	1-216-851-11	METAL GLAZE	330K	5%	1/16W	
R413	1-216-851-11	METAL GLAZE	330K	5%	1/16W	
R414	1-216-857-11	METAL GLAZE	1M	5%	1/16W	
R415	1-216-841-11	METAL GLAZE	47K	5%	1/16W	
R416	1-216-851-11	METAL GLAZE	330K	5%	1/16W	
R417	1-216-819-11	METAL GLAZE	680	5%	1/16W	
R418	1-216-837-11	METAL GLAZE	22K	5%	1/16W	
R419	1-216-833-11	METAL GLAZE	10K	5%	1/16W	
R420	1-216-833-11	METAL GLAZE	10K	5%	1/16W	
R421	1-216-851-11	METAL GLAZE	330K	5%	1/16W	
R422	1-216-851-11	METAL GLAZE	330K	5%	1/16W	
R423	1-216-837-11	METAL GLAZE	22K	5%	1/16W	
R424	1-216-819-11	METAL GLAZE	680	5%	1/16W	
R425	1-216-805-11	METAL GLAZE	47	5%	1/16W	
R426	1-216-821-11	METAL GLAZE	1K	5%	1/16W	
R427	1-216-821-11	METAL GLAZE	1K	5%	1/16W	
R428	1-216-851-11	METAL GLAZE	330K	5%	1/16W	
R429	1-216-845-11	METAL GLAZE	100K	5%	1/16W	
R434	1-216-853-11	METAL GLAZE	470K	5%	1/16W	
R436	1-216-845-11	METAL GLAZE	100K	5%	1/16W	
R437	1-216-845-11	METAL GLAZE	100K	5%	1/16W	
R438	1-216-025-00	METAL GLAZE	100	5%	1/10W	
R439	1-216-837-11	METAL GLAZE	22K	5%	1/16W	
R440	1-216-813-11	METAL GLAZE	220	5%	1/16W	
R441	1-216-813-11	METAL GLAZE	220	5%	1/16W	
R442	1-216-837-11	METAL GLAZE	22K	5%	1/16W	
R443	1-216-851-11	METAL GLAZE	330K	5%	1/16W	
R444	1-216-833-11	METAL GLAZE	10K	5%	1/16W	
R445	1-216-839-11	METAL GLAZE	33K	5%	1/16W	
R446	1-216-833-11	METAL GLAZE	10K	5%	1/16W	
R447	1-216-833-11	METAL GLAZE	10K	5%	1/16W	
R448	1-216-851-11	METAL GLAZE	330K	5%	1/16W	
R449	1-216-833-11	METAL GLAZE	10K	5%	1/16W	
R450	1-216-851-11	METAL GLAZE	330K	5%	1/16W	
R451	1-216-857-11	METAL GLAZE	1M	5%	1/16W	
R452	1-216-851-11	METAL GLAZE	330K	5%	1/16W	
R453	1-216-841-11	METAL GLAZE	47K	5%	1/16W	
R454	1-216-085-00	METAL GLAZE	33K	5%	1/10W	

Ref.No.	Part No.	Description			
R455	1-216-797-11	METAL GLAZE	10	5%	1/16W
R456	1-216-797-11	METAL GLAZE	10	5%	1/16W
R457	1-216-829-11	METAL GLAZE	4.7K	5%	1/16W
R458	1-216-857-11	METAL GLAZE	1M	5%	1/16W
R459	1-216-845-11	METAL GLAZE	100K	5%	1/16W
R460	1-216-840-11	METAL GLAZE	39K	5%	1/16W
R601	1-217-671-11	METAL GLAZE	1	5%	1/10W
R602	1-216-993-11	METAL GLAZE	2.4K	5%	1/16W
R603	1-216-829-11	METAL GLAZE	4.7K	5%	1/16W
RV101	1-228-358-00	RES, ADJ, METAL GLAZE	2.2K		LEVEL (L)
RV201	1-228-358-00	RES, ADJ, METAL GLAZE	2.2K		LEVEL (R)
RV301	1-230-485-21	RES, VAR, CARBON	10K/10K		VOL
RV601	1-230-602-11	RES, ADJ, METAL GLAZE	4.7K		SPEED
S301	1-570-396-11	SWITCH, SLIDE (DIR)			
S302	1-571-275-21	SWITCH, SLIDE (TAPE)			
S303	1-571-275-21	SWITCH, SLIDE (DOLBY NR)			
S304	1-571-506-21	SWITCH, SLIDE (DBB)			
S401	1-570-395-11	SWITCH, LEAF (HEAD POSITION)			
S402	1-570-204-21	SWITCH, KEY BOARD (DIR)			
S403	1-570-204-21	SWITCH, KEY BOARD (PLAY/STOP)			
S404	1-571-275-21	SWITCH, SLIDE (REMOTE)			
S405	1-571-275-21	SWITCH, SLIDE (MODE)			
S406	1-570-548-11	SWITCH, LEAF (POWER)			
THP601	1-808-039-11	THERMISTOR, POSITIVE			
THP602	1-808-024-11	THERMISTOR, POSITIVE			

ACCESSORY & PACKING MATERIAL

1-236-177-11	PLUG UNIT (CHARGE)
△1-526-565-00	(E)...AC PLUG ADAPTOR
1-528-231-11	BATTERY, NICKEL CADMIUM (NC-6WM)
△1-528-234-11	(E)...BATTERY CHARGER (BC-7L)
△1-528-251-11	(AEP)...BATTERY CHARGER (BC-7S)
△1-528-252-11	(UK)...BATTERY CHARGER (BC-7S)
3-337-981-01	CASE, CARRYING
*3-344-680-01	CUSHION (UPPER)
*3-344-681-01	CUSHION (LOWER)
*3-344-698-01	(E)... INDIVIDUAL CARTON
*3-344-699-01	(AEP,UK)...INDIVIDUAL CARTON
8-952-383-90	(E)... (BLACK)...EARPHONE MDR-454RV
8-952-383-91	(E)... (WHITE)...EARPHONE MDR-454RV
8-952-407-90	(AEP,UK)... (BLACK)...EARPHONE MDR-A20RV
8-952-407-91	(AEP,UK)... (WHITE)...EARPHONE MDR-A20RV

Note: The components identified by mark Δ or dotted line with mark Δ are critical for safety. Replace only with part number specified.

WM-509

SONY SERVICE MANUAL

AEP Model
UK Model
E Model

SUPPLEMENT-1

There are two types of pinch lever, and one is metal type and the other is plastic mould type. (Service Manual shows the plastic mould type.)
Following table shows the difference.

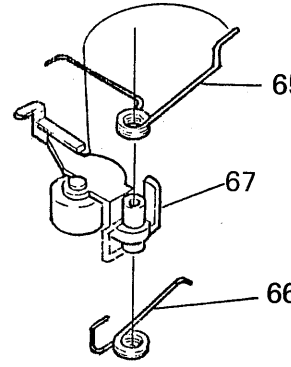
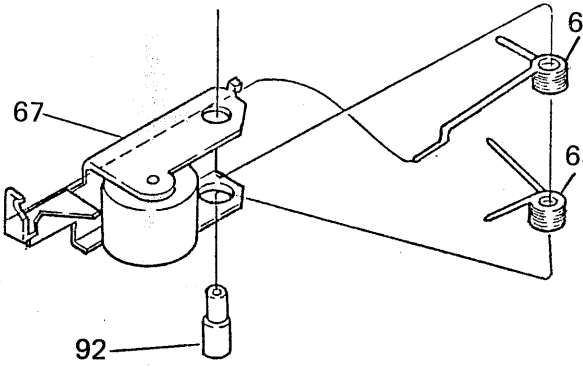
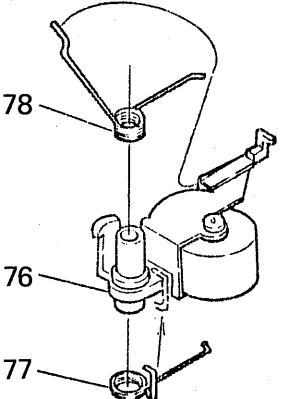
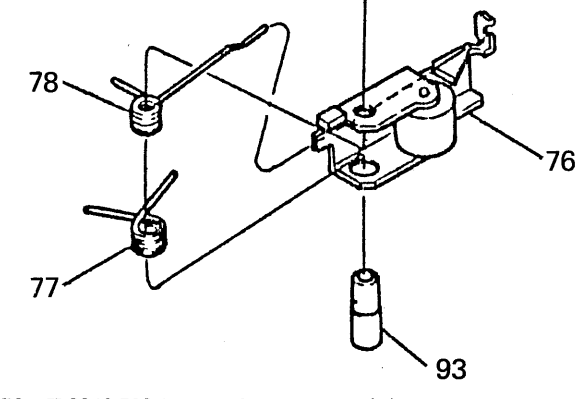
Page	Plastic mould type	Metal type
15	 <p>65 3-341-470-01 SPRING (N) 66 3-341-469-01 SPRING (N) 67 X-3331-036-1 PINCH LEVER (N) ASSY</p>	 <p>65 3-342-516-01 SPRING, TORSION 66 3-341-431-02 SPRING (NB) 67 X-3342-522-1 PINCH LEVER (N) ASSY 92 3-329-637-01 COLLAR, PINCH LEVER</p>
	 <p>76 X-3331-035-1 PINCH LEVER (R) ASSY 77 3-341-468-01 SPRING (R) 78 3-341-467-01 SPRING (R)</p>	 <p>76 X-3342-508-1 PINCH LEVER (R) ASSY 77 3-347-246-02 SPRING (PINCH R), TORSION 78 3-329-643-01 SPRING (R) 93 3-331-027-01 COLLAR (R), PINCH LEVER</p>